

# D016

## Complex Structure Dog Series III

### INFORMATION ABOUT PRODUCT

Dimensions	280x255 cm
Overall Height	105 cm
Foundations	12 pcs
Availability of spare parts	YES

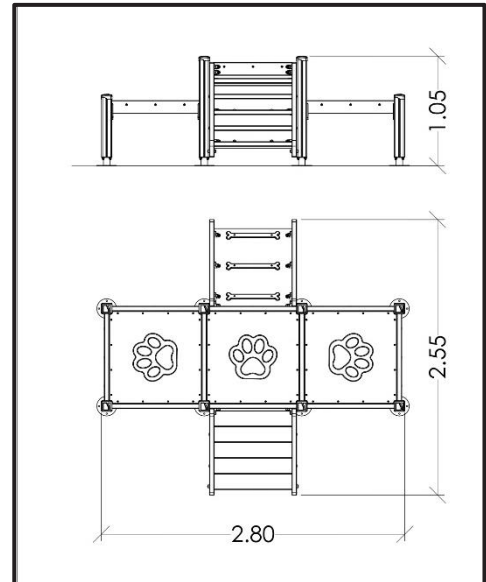

### MATERIALS

- Posts: Laminated pine wood 95x95mm
- Post cups made of Fiber - Reinforced Plastic
- Floors: HPL Antiskid 12mm (EXT) and or Antiskid Plywood (EXT) 21mm
- Panels: HPL 12mm (EXT) and or Birch Plywood (EXT) 18mm
- Wooden elements: Pine wood
- Metal Parts (colored): Hot Dip Galvanized and or Zinc Primer prior to Powder Coated plating.
- Metal Parts (non - colored): Hot Dip Galvanized (plain) or Stainless Steel (304 / 316L)
- Steel Ropes apparatus: Steel core ropes braided with polypropylene (Ø16mm). Solid and aesthetic connectors made of injection molded durable plastic / end-connectors and sleeves made of durable aluminum alloy
- All other plastic elements: Fiber reinforced plastic
- Fasteners: Electroplated coated or Stainless Steel (304 / 316L)
- Chains: Hot Dip Galvanized (plain) or Stainless Steel (304 / 316L) / Ø6mm / According to DIN 766
- Plastic Tunnel: Co-Extruded stabilized HDPE, consisting of two walls (one corrugated exterior and one smooth interior) / SN 8 Stiffness /



***Please note that the above list of materials concerns the articles of the whole series. Therefore, some of them are not used in the described article.***